

Impedance-Balancing Rule for Op-Amps

This note by **David Gibson**, demonstrates a rule that aids circuit design by allowing the component values around multi-input summing amplifiers or comparators to be easily calculated. The rule states: "The gain from any input of a summing amplifier is simply the feedback impedance divided by that input impedance, provided that the sum of the admittances connected to the inverting input of the op-amp is equal to the sum of the admittances connected to the non-inverting input. Given this condition, amplifier bias currents will not contribute an error".

This note was first published 27 years ago in 1991 [1] and again in 1993 [2], in two relatively obscure journals. Now, in 2018, I have scanned and re-formatted the original text, because I still think that it describes a useful tool for the electronic circuit designer.

A new and simple rule aids circuit design by allowing the component values around multi-input summing amplifiers or comparators to be easily calculated. It can be applied where an op-amp sums two or more signals using both its inputs, or where a bias voltage is applied to either terminal. I have not seen this rule quoted previously and venture to suggest that it is novel – it is, at any rate, extremely useful.

Calculating component values can be difficult or tedious, especially where the signal channels require different gains and have complex impedance. *Figure 1* is an example of a 'difficult' design where three signals need to be summed and filtered. Only the first step, calculating the input resistor for U_B , is easy; calculating the remaining component values is tedious and error-prone, because the voltage at the positive input terminal needs to be calculated as part of the process. The rule states ...

The gain from any input of a summing amplifier is the feedback impedance divided by that input impedance, provided that the sum of the admittances connected to the inverting input of the amplifier is equal to the sum of the admittances connected to the non-inverting input. Given this condition, amplifier bias currents will not contribute an error.

This rule should perhaps be called the admittance balancing rule, but admittance is simply the reciprocal of impedance. The impedances do not have to be resistive, but must (of course) take into account the signal source impedance. Feedback admittance is treated as just another admittance connected to the inverting input.

Applying the rule to *Figure 1* is simple. The input resistances are immediately known (*Figure 2*), and all that remains is to 'balance' the impedance at each input by connecting a capacitor C_{BAL} from the positive input to ground, and a resistor R_{BAL} from the negative input to ground. Ground is treated as just another input, but being at 0V it contributes nothing to the output. The values required are therefore $C_{BAL} = C_F = 10$ nF and $R_{BAL} = 3.33$ k Ω .

Notice that there are no unique values for R_{BAL} and C_{BAL} – a combination of a 5 k Ω resistor from the positive input to ground, and a 2 k Ω resistor from the negative input to ground would provide a clearer representation of the required condition.

Effect of Unbalancing: It may not always be possible to balance the impedances, and this condition can be stated as ...

If the impedances are not balanced then the gains of all the channels connected to the positive input is greater by a factor equal to the ratio of the sum of the admittances connected to the inverting input of the op-amp divided by the sum of the admittances connected to the non-inverting input, provided that the amplifier input currents (bias and offset) are negligible.

The easiest way to achieve a balance is to make sure that the same values of component are connected to both inputs. If this is not possible then some compromise in component values may

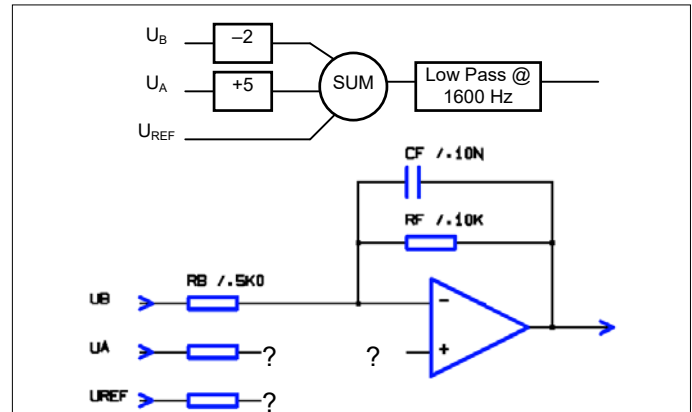

Figure 1 – A "difficult" design of amplifier
In the block diagram, above, three signals need to be summed and filtered. In the op-amp implementation, only the first step, calculating the input resistor for U_B , is easy. Calculating the remaining component values is tedious and error-prone.

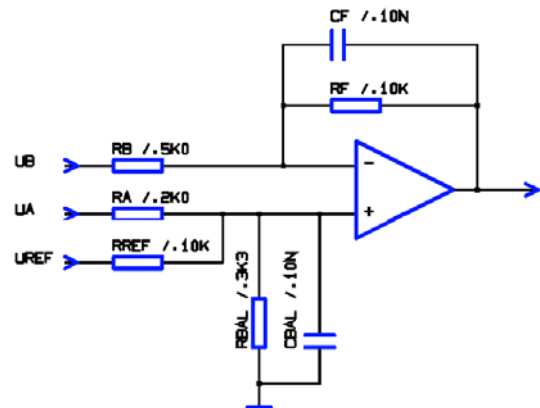

Figure 2 – A practical implementation of Fig.1
Components R_{BAL} and C_{BAL} are included to balance the impedances and lead to the correct gains from each input.

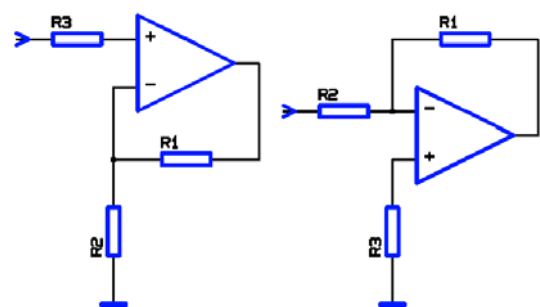

Figure 3 – Eliminating the effect of bias current
The Impedance Balancing Rule leads to the familiar requirement for the elimination of bias current effects, namely that $R_3 = R_1 || R_2$

need to be made. Additionally, it may be decided to omit a high value balancing component that would give rise to a low error.

Bias Currents: A consequence of the rule is that the op-amp's input currents flow in equal impedances and thus contribute the minimum to offset voltage. Applying the rule to a single input amplifier (*Figure 3*) leads, by an unfamiliar route, to the familiar configuration for minimum effect of bias current, which is that R_3

is equal to the combination of R1 and R2 in parallel. Note that, in this case, the gain of the non-inverting amplifier is – according to the impedance balancing rule – equal to R1/R3.

Analysis

The analysis is straightforward. Referring to *Figure 4*, the input currents are denoted by I_A, I_B ; the input voltages and impedances for the non-inverting input by U_{Ai}, Z_{Ai} ; those for the inverting input as U_{Bi}, Z_{Bi} ; and the voltage at the amplifier input terminals (usual ‘ideal’ assumptions) by U_X . The currents at each op-amp input are summed, as follows.

$$I_A + \frac{U_{A1} - U_X}{Z_{A1}} + \frac{U_{A2} - U_X}{Z_{A2}} + \dots = 0 \quad (1)$$

$$\text{and } I_B + \frac{U_{B1} - U_X}{Z_{B1}} + \frac{U_{B2} - U_X}{Z_{B2}} + \dots + \frac{U_{OUT} - U_X}{Z_F} = 0 \quad (2)$$

Re-arranging to obtain U_X we have

$$U_X \sum_i \frac{1}{Z_{Ai}} = I_A + \sum_i \frac{U_{Ai}}{Z_{Ai}} \quad (3)$$

$$\text{and } U_X \sum_i \frac{1}{Z_{Bi}} + \frac{U_X}{Z_F} = I_B + \sum_i \frac{U_{Bi}}{Z_{Bi}} + \frac{U_{OUT}}{Z_F} \quad (4)$$

U_X can now be eliminated from (3) and (4), and U_{OUT} written as

$$\frac{U_{OUT}}{Z_F} = K \sum_i \frac{U_{Ai}}{Z_{Ai}} - \sum_i \frac{U_{Bi}}{Z_{Bi}} \quad (5)$$

$$\text{where } K = \left(\sum_i \frac{1}{Z_{Bi}} + \frac{1}{Z_F} + I_B \right) / \left(\sum_i \frac{1}{Z_{Ai}} + I_A \right) \quad (6)$$

The rule requires K to be 1. Equation (6) shows that the condition for this is that the sum of the admittances connected to the inverting and non-inverting inputs are equal. In addition, I_A must be equal to I_B . For bias currents this is true by definition, so apart from the contribution from offset current, and provided that the impedance balancing condition is met, the amplifier input currents do not contribute to gain errors. The gain can thus be written as (5) with $K=1$.

If the circuit is unbalanced, then (5) still describes the rule, but with the weighting factor, K , defined as in (6); and in the definition given in the text, above.

Example of Use

In an article in the magazine *Electronics World*, [back in the 1990s] an author claimed to have designed a filter “similar in arrangement to a Sallen & Key filter, [using] four components instead of six”. This statement immediately strikes one as ‘dubious’ because the Sallen & Key design is a filter *topology*, not a type of filter response; and furthermore, can be implemented with four components quite satisfactorily.

A quick analysis of the author’s circuit is possible using the impedance balancing rule, and it is easily shown that he is mistaken. The circuit in question is shown in *Figure 5*, where the author claimed, additionally, that swapping the R s and C s would result in a high-pass instead of a low-pass filter.

Analysis of Filter Circuit: A full algebraic analysis of the circuit would be straightforward but tedious. It can be simplified, somewhat, by assuming that $R_1 = R_3$ and $C_2 = C_4$; and then reduced to a trivial problem by using the impedance balancing rule. With this condition, the impedance ‘seen’ by the inverting input of the

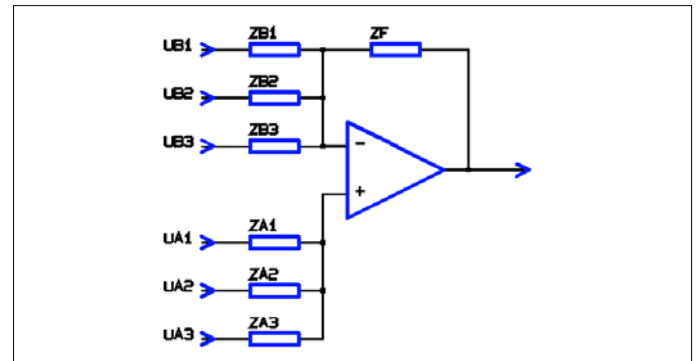

Figure 4 – The Impedance Balancing Rule
The gain from each input is given by Z_F divided by the input impedance provided that the balancing condition is met, as described in the text.

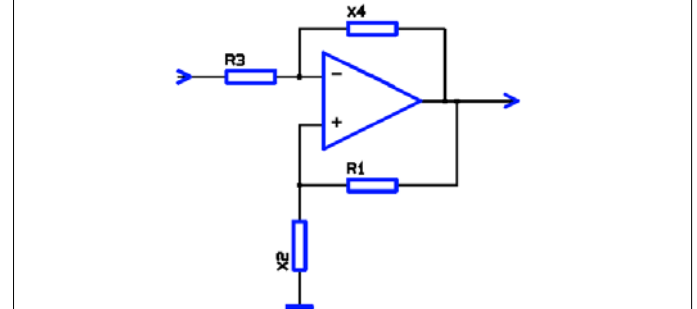

Figure 5 – Analysing an unknown circuit function
It was claimed that this published circuit was a second-order low-pass filter. However, an analysis (made easier by using the impedance balancing rule) swiftly shows this not to be the case.

amplifier is equal to the impedance ‘seen’ by the non-inverting input. In other words, the sums of the admittances connected to the two inputs are the same. The gain from each ‘input’ is now simply the feedback impedance divided by the impedance connected to that input, so we have

$$V_{out} = -\frac{X_4}{R_3} V_{in} + \frac{X_4}{R_1} V_{out} \quad (1)$$

from which we can immediately write (with $X = 1/sC$),

$$\frac{V_{out}}{V_{in}} = \frac{1}{1 - sCR} \quad (2)$$

which, whatever else it might be, is not a second-order low pass filter “similar to a Sallen & Key filter”. In fact, it is a first order low pass filter combined with a first-order all-pass phase shift network, i.e.

$$\frac{V_{out}}{V_{in}} = \frac{1}{1 + sCR} \frac{1 + sCR}{1 - sCR} \quad (3)$$

Swapping the R s and C s results in a filter which is a first-order high-pass in conjunction with an all-pass network, i.e.

$$\frac{V_{out}}{V_{in}} = \frac{-sCR}{1 + sCR} \frac{1 + sCR}{1 - sCR} \quad (4)$$

The impedance balancing rule thus provides a very quick method of analysing such a circuit. In this case it shows that it was not what the author stated, although exactly what he meant by “similar to a Sallen & Key filter” is not known. ■

References

- Gibson, D (1991). Impedance Balancing Rule for Op-amps, *Electronic Product Design* 12 (7), p17-19. ISSN 0263-1474
- Gibson, D. (1993). Ruling Principle for Balancing Op-amps, *Electronics & Wireless World*, 99(1689), p673-674 (August 1992). ISSN 0959-8332.